

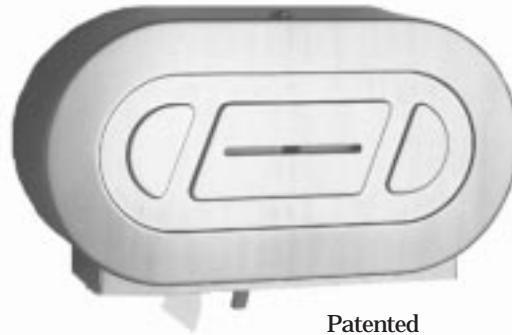

Technical Data

STAINLESS STEEL TWIN JUMBO-ROLL TOILET TISSUE DISPENSER

B-2892



Patented

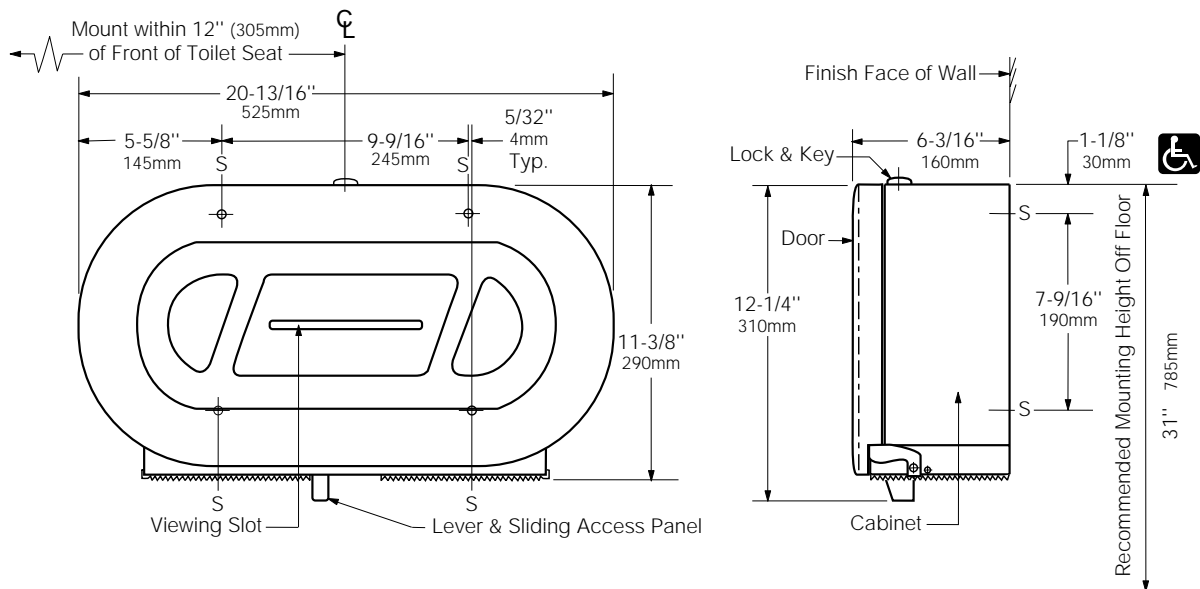

MATERIAL:

Cabinet — 18-8 S, type-304, 20-gauge (1.0mm) stainless steel with satin finish. Equipped with a tumbler lock keyed like other Bobrick washroom accessories.

Door — 18-8 S, type-304, 18-gauge (1.2mm) stainless steel with satin finish. Drawn, one-piece, seamless construction. Wide viewing slot reveals toilet tissue supply inside cabinet.

Dispensing Mechanism — High-impact rigid vinyl. Chemical-resistant and flame-retardant.

OPERATION:

Door unlocks with key provided and swings down for loading dispenser. Spindles accommodate two toilet tissue rolls up to 10" (255mm) diameter with 3" (75mm) diameter core, or remove outer spindle (which is held in place with 3 snags) from the inner spindles to accommodate 2-1/4" (55mm) diameter core rolls. Unique sliding access panel exposes one roll at a time for patron use, assuring uninterrupted, complete no-waste use of first roll before starting the reserve roll; allows easy roll change-over. When first roll is depleted, move the lever at the bottom of dispenser to the left until sliding access panel locks in position and exposes roll on right. When door is opened for reloading, the sliding access panel automatically releases and returns to the original position on the right. Move the remaining roll to the first position on left and install a new roll on the right spindle. Wide viewing slot in door reveals the amount of toilet tissue on both rolls. Unit is designed for quick reloading.

continued...

INSTALLATION:

Mount unit on wall or toilet partition with four sheet-metal screws, furnished by manufacturer, at points indicated by an *S*. Rear edge of unit should be 20" (510mm) from back wall. This locates toilet tissue within 12" (305mm) of front of standard toilet that projects 30" (760mm) from back wall.

For plaster or dry wall construction, provide concealed backing to comply with local building codes, then secure unit with sheet-metal screws furnished. For other wall surfaces, provide fiber plugs or expansion shields for use with sheet-metal screws furnished, or provide 1/4" (6mm) toggle bolts or expansion bolts.

For partitions with particle-board or other solid core, secure with sheet-metal screws or provide through-bolts, nuts, and washers. For hollow-core metal partitions, provide solid backing into which sheet-metal screws can be secured. If two units are installed back-to-back, then provide threaded sleeves and machine screws for the full thickness of partition.

SPECIFICATION:

Jumbo-roll toilet tissue dispenser door and cabinet shall be type-304 stainless steel with satin finish: door shall be 18 gauge (1.2mm); cabinet shall be 20 gauge (1.0mm). Cabinet shall be equipped with a tumbler lock keyed like other Bobrick washroom accessories. Door shall have a wide viewing slot to reveal toilet tissue supply inside cabinet. Dispensing mechanism shall be constructed of high-impact, chemical-resistant, flame-retardant rigid vinyl; shall accommodate two toilet tissue rolls up to 10" (255mm) diameter with 3" (75mm) diameter core; and be equipped with a sliding access panel that exposes one roll at a time. Spindles shall be convertible in the field to dispense 2-1/4" (55mm) diameter core rolls by removing outer spindles furnished in-place. Manufacturer's service and parts manual shall be provided to the building owner/manager upon completion of project.

Twin Jumbo-Roll Toilet Tissue Dispenser shall be Model B-2892 of Bobrick Washroom Equipment, Inc., Clifton Park, New York; Jackson, Tennessee; Los Angeles, California; Bobrick Washroom Equipment of Canada Ltd., Scarborough, Ontario; Bobrick Washroom Equipment Pty. Ltd., Australia; and Bobrick Washroom Equipment Limited, United Kingdom.